

4

3

2

REV NC SH 1 DWG NO. C1D-1614-089-1

THIS DOCUMENT CONTAINS PROPRIETARY INFORMATION AND EXCEPT WITH WRITTEN PERMISSION OF TRI-STAR ELECTRONICS INT'L, INC., SUCH INFORMATION SHALL NOT BE PUBLISHED, OR DISCLOSED TO OTHERS, OR USED FOR ANY PURPOSE, AND THE DOCUMENT SHALL NOT BE DUPLICATED IN WHOLE OR IN PART.

REVISIONS				
ZONE	LTR	DESCRIPTION	DATE	APPD
NC		NEW RELEASE PER E.O. 21917	11/13/12	JK

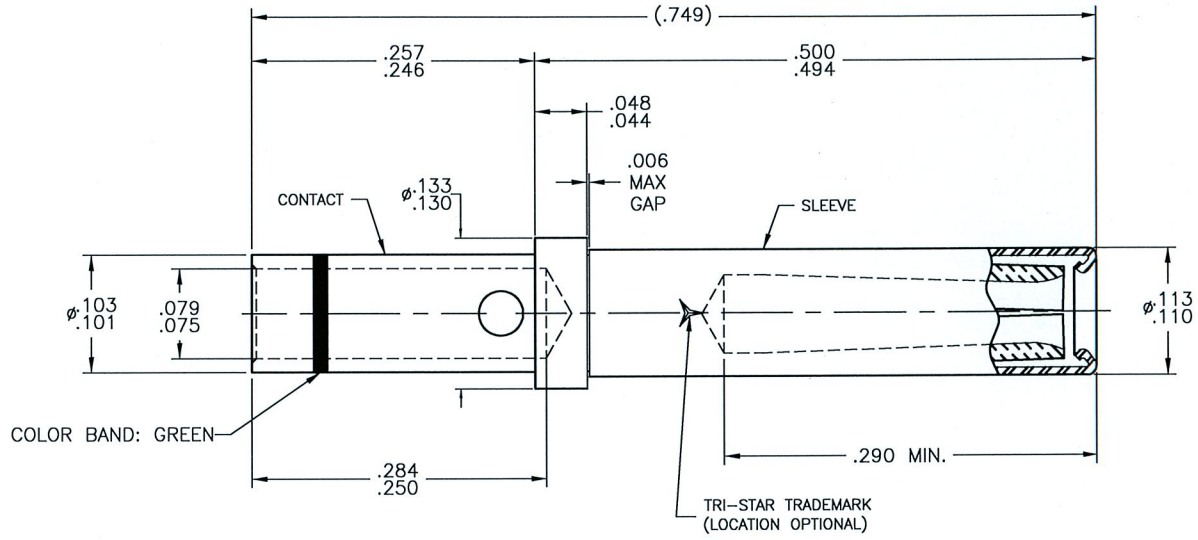

4. ENGAGEMENT AND SEPARATION FORCES PER AS39029.

3 FINISH: CONTACT - NICKEL PLATE PER QQ-N-290, CLASS 1, (.000120 MIN. THK.) OVER .000030 MIN. THK. COPPER PLATE PER AMS-2418.

2 MATERIAL: CONTACT: SUITABLE COPPER ALLOY PER AS39029. SLEEVE: STAINLESS STEEL, PASSIVATED

1. www.tri-starelectronics.com

NOTES: (UNLESS OTHERWISE SPECIFIED)

SALES DRAWING

REF.	DESCRIPTION	USED ON
1	NEXT ASSEMBLY	
2	APPLICATION	

QTY REQD	FORM NO.	PART OR IDENTIFYING NO.	NOMENCLATURE OR DESCRIPTION	MATERIAL SPECIFICATION	ITEM NO.
PARTS LIST					
UNLESS OTHERWISE SPECIFIED DIMENSIONS ARE IN INCHES. TOLERANCES ARE:		CONTRACT NO.		TRI-STAR ELECTRONICS INT'L, INC. 2201 ROSECRANS AVENUE, EL SEGUNDO, CA 90245	
ANGLES ±30' .XX ±.01 .XXX ±.005		RATING:			
DO NOT SCALE DRAWING		APPROVALS		DWG TITLE	
MATERIAL: 2	TREATMENT:	DATE	DATE	CONTACT, ELECTRICAL CONNECTOR SOCKET, CRIMP REMOVABLE, #16-14	
FINISH: 3		11-12-12	11/12/12		
REF:		CHECKED: S. JONES	DATE: 11-13-12	SIZE: A	CAGE CODE: 55104
		APPROVED: JK	DATE: 11/13/12	DWG NO.:	C1D-1614-089-1
				REV: NC	
				SCALE: NONE	CAD NO: 6.25X-
				SHEET 1	OF 1

4

3

2

1