

4

3

2

REV B SH 1 DWG NO. C19-2018-088

THIS DOCUMENT CONTAINS PROPRIETARY INFORMATION AND EXCEPT WITH WRITTEN PERMISSION OF TRI-STAR ELECTRONICS INT'L, INC., SUCH INFORMATION SHALL NOT BE PUBLISHED, OR DISCLOSED TO OTHERS, OR USED FOR ANY PURPOSE, AND THE DOCUMENT SHALL NOT BE DUPLICATED IN WHOLE OR IN PART.

REVISIONS

ZONE	LTR	DESCRIPTION	DATE	APPD
	NC	NEW RELEASE PER E.O. 20624	11/23/10	H. LE
	A	REVISED PER E.O. 21575	5/22/12	J.K.
	B	REVISED PER E.O. 21665	7/16/12	J.K.

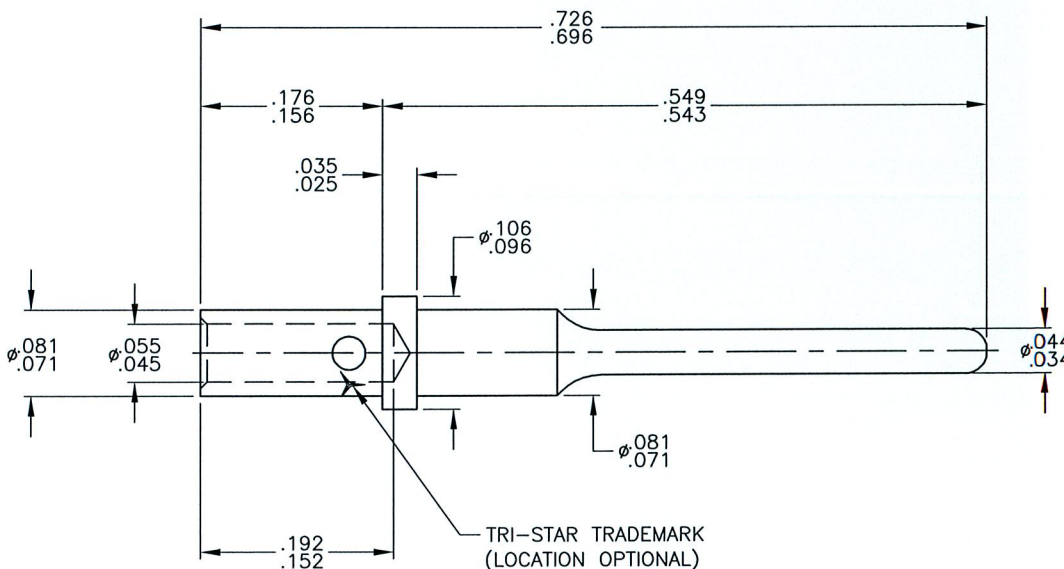

4. CRIMP TOOL DATA:
BASIC CRIMP TOOL: M22520/2-01
POSITIONER: M22520/2-02

3. FINISH: BRIGHT NICKEL PLATE PER AMS-QQ-N-290.

2. MATERIAL: SUITABLE COPPER ALLOY PER AS39029.

1. www.tri-starelectronics.com

NOTES: (UNLESS OTHERWISE SPECIFIED)

SALES DRAWING

QTY REQD	FSCM NO.	PART OR IDENTIFYING NO.	NOMENCLATURE OR DESCRIPTION	MATERIAL SPECIFICATION	ITEM NO.
			PARTS LIST		
UNLESS OTHERWISE SPECIFIED DIMENSIONS ARE IN INCHES. TOLERANCES ARE:		CONTRACT NO.		TRI-STAR ELECTRONICS INT'L, INC. 2201 ROSECRANS AVENUE, EL SEGUNDO, CA 90245	
ANGLES .XX .XXX $\pm .30'$ $\pm .01$ $\pm .005$		RATING:		DWG TITLE	
DO NOT SCALE DRAWING		APPROVALS		CONTACT, ELECTRICAL CONNECTOR, PIN CRIMP REMOVABLE	
MATERIAL: TREATMENT: FINISH:		DATE		SIZE	
2 3		DRAWN: F. RODRIGUEZ 11-16-10		CAGE CODE 55104	
REF:		CHECKED: C.P. 11-23-10		DWG NO. C19-2018-088	
NEXT ASSEMBLY USED ON		APPROVED: H. LE 11-23-10		REV B	
APPLICATION		APPROVED:		SCALE: NONE CAD NO: 6.25X- SHEET 1 OF 1	

E:\CONT.CAD.FILES\PIN\FINISH\C19-2018-088

4

3

2

1